



100 % of MTB's expertise and performance in a compact system

COMPACT SYSTEM



Plug'n'Run

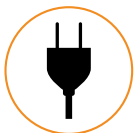

COMPACT SYSTEM

TURNKEY RECYCLING PLANT



Our recycling box solutions

Plug'n'run

Ready to use, our range of boxes integrate a complete recycling line within combined containers.

Compact, mobile, efficient and economical, the BOX's achievement is to retain all the equipment of a standard MTB recycling line and condense it all in containers.

This concept of Plug'n'Run is fully integrated and ready for use without any assembly operation required. Only a connection of containers will be necessary.

Equipment that is easily transportable and offers fast commissioning.

CABLEBOX

The SHRED' BOX

This part of the process includes:

A shredding unit, which consists of an extremely robust and powerful compact shredder, able to process all common cables, including difficult cables, either copper or aluminum.

A granulation module, which includes two granulators reducing the size of the material to achieve the optimum sorting size.

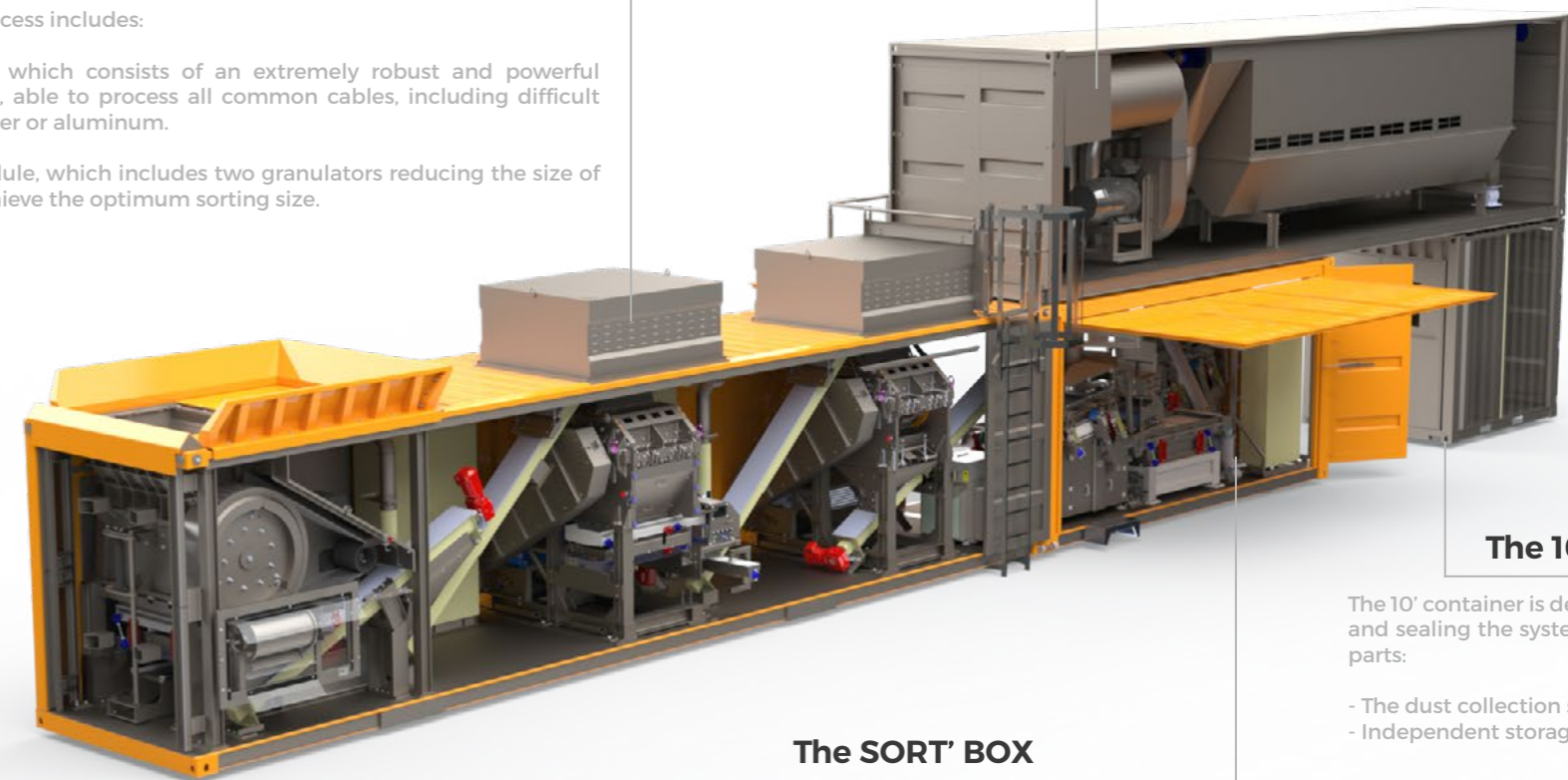

The AIR' BOX

In order to maintain a quick process and easy installation procedures, MTB has equipped the system with an air filtration unit in a separate container. Despite its relative compactness, the AIR'BOX contains a powerful dust collection system essential for an optimized separation of products.

The 10' CONTAINER

The 10' container is dedicated to dust collection and sealing the system. The box is divided in 2 parts:

- The dust collection section
- Independent storage for spare parts or tools

The SORT' BOX

This space is composed of density air tables, sieving tables and magnetic pulleys, which is similar to larger scale recycling lines. It allows the recovery of sorted material at the end of the process as follows: ferrous scrap, big copper nugget, copper fine fraction, caps (aluminum, brass, tin) and plastic.

APPLICATION SPECIALTIES



CABLES



SHREDDED WIRES



TRANSFORMER WIRE

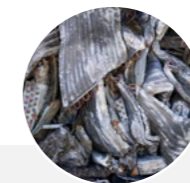

RADIATORS

CAPACITY
From **1 to 3 T/h**

COMPOSITION

SHREDDING



Compact Shredder : BDR 1245

GRANULATION



x2 Compact Granulators :
BAT 845

SORTING



x2 Air Density Tables :
T600 x 1200



x2 Sieving Tables :
TAM 700

FERROUS
EXTRACTION



Magnetic Separator

Advantages

COMPACT & GREEN

- Turnkey cable recycling line within containers
- Designed with an enclosed style system to reduce dust emissions drastically
- Intuitive and integrated monitoring system

MINIMUM SIZE - MAXIMUM EFFICIENCY

- Feeding either by crane or dosing conveyor
- MTB's Heavy Duty machines
- Designed to reach up to 3 metric tons per hour capacity - may vary upon cable quality
- Output products: ferrous, non-ferrous and plastic

PLUG & RECYCLE

- User-friendly, just plug in and start recycling
- 1 assembly operation only: the external 11 770 CFM dust extraction unit (20 000 m³/h)
- Personalized customer support: Training of operators before BOX installation

OPTIONS

- Hydraulic system for BDR 1245 and swing doors
- Set of output belts conveyor or screws conveyors for easy conditioning of chops
- Plastic screening stage
- Automatic bin feeder with visual control and level sensor

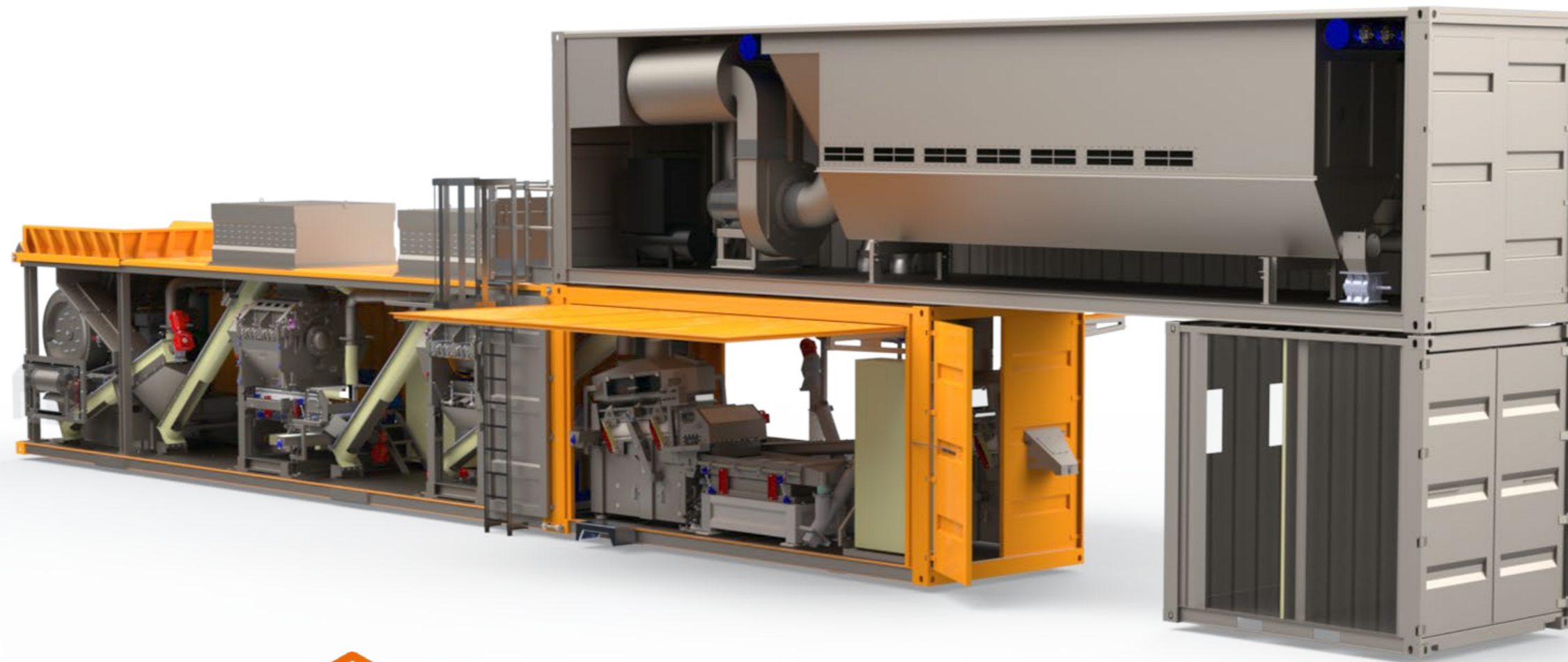

CLASSIFIED OUTPUT PRODUCTS*



BIG COPPER



FINE COPPER

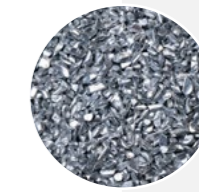

ALUMINUM



NFE FLAKES



PLASTIC

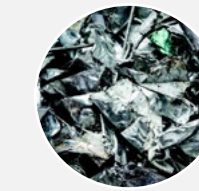

FERROUS INSERT

* Classified non ferrous grades, ferrous, plastics



CABLE BOX®

Technical Data



TECHNICAL DATA	CABLEBOX	SHRED'BOX 40'	SORT'BOX 20'	AIR'BOX 40'	10' CONTAINER	Main equipment specs.	
						PRESHREDDER	GRANULATOR
Length	80' 05" / 24,40 m	39' 12" / 12,19 m	19' 10" / 6,06 m	39' 12" / 12,19 m	9' 8" / 2,99 m	-	-
Width	8' / 2,44 m	8' / 2,44 m	8' / 2,44 m	8' / 2,44 m	8' / 2,44 m	-	-
Height	19' 20" / 5,80 m	9' 6" / 2,90 m	9' 6" / 2,90 m	9' 6" / 2,90 m	9' 6" / 2,90 m	-	-
Power	500 Hp / 375 kW	345 Hp / 253 kW	35 Hp / 26 kW	125 Hp / 90 kW	-	125 Hp / 90 kW	100 Hp / 75 kW
Weight	121 000 lb / 54T	66 000 lb / 31 T	22 000 lb / 9T	24 000 lb / 11T	6 600 lb / 3T	16 000 lb / 7,5T	12 000 lb / 5,5T
Cutting speed	-	-	-	-	-	140 - 180 RPM	150 - 375 RPM
Rotor length	-	-	-	-	-	49" / 1 245 mm	32" / 800 mm
Blades	-	-	-	-	-	24	28

Non contractual data



CABLE BOX ONE

SHREDDING

This space of the process includes:

A shredding module, which consists of an extremely robust and powerful compact shredder, equipped with a horizontal pusher for better productivity.

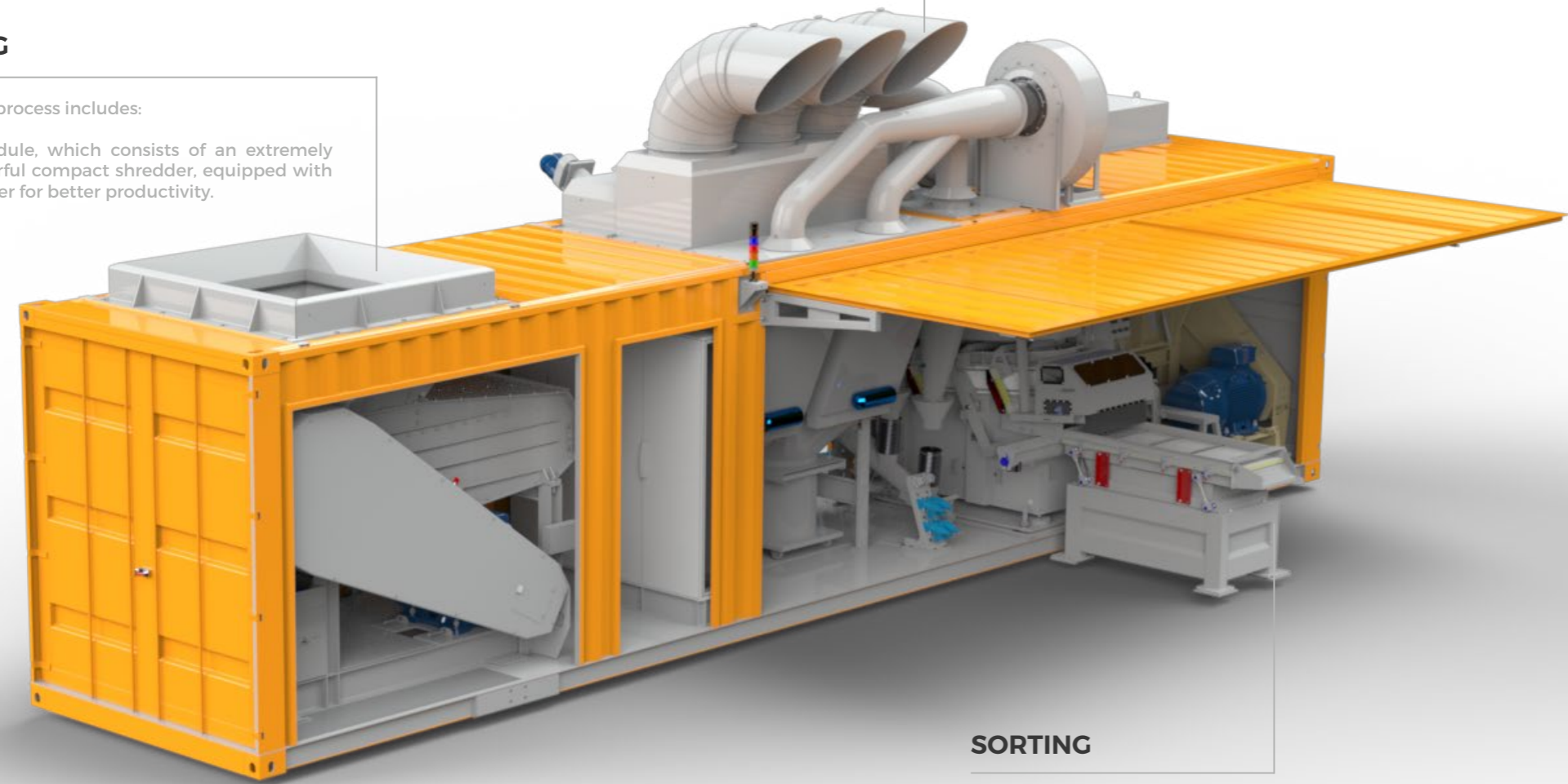

AIR DEDUSTING SYSTEM

SORTING

This space is composed of a density air table, a sieving table and a magnetic pulley. It allows the recovery of sorted material at the end of the process as follows: ferrous scrap, big copper nugget, copper fine fraction, caps (aluminum, brass, tin) and plastic.

APPLICATION SPECIALTIES



CABLES



SHREDDED WIRES



ACSR

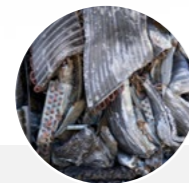

RADIATORS



INDUSTRIAL WASTE

CAPACITY
up to **2 T/h**

COMPOSITION

SHREDDING



Compact Shredder : BVR 1200

GRANULATION



Compact Granulator :
BAT 845

SORTING



Air Density Table :
T600 x 1200



Sieving Table :
TAM 700

FERROUS EXTRACTION



Magnetic Separator

CLASSIFIED OUTPUT PRODUCTS*



BIG COPPER



FINE COPPER



ALUMINUM



NFE FLAKES



PLASTIC

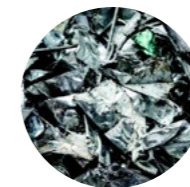

FERROUS INSERT

* Classified non ferrous grades, ferrous,



CABLEBOX ONE

Advantages

MINIMUM SIZE - MAXIMUM EFFICIENCY

- Feeding either by crane, belt conveyor or fork lift
- MTB's Heavy Duty machines
- Power and reliability for both granulation and sorting
- Designed to reach up to 0,5 to 2 tons per hour capacity may vary upon cable quality
- Output products: ferrous, non-ferrous and plastic
- Automatic bin feeder with visual control and level sensor

COMPACT & GREEN

- Turnkey cable recycling line in a container
- Designed to reduce dust emissions drastically
- Intuitive and integrated monitoring system

PLUG & RECYCLE

- User-friendly, just plug in and start recycling
- No assembly operation, time is money!
- Training of operators before BOX installation



Technical Data

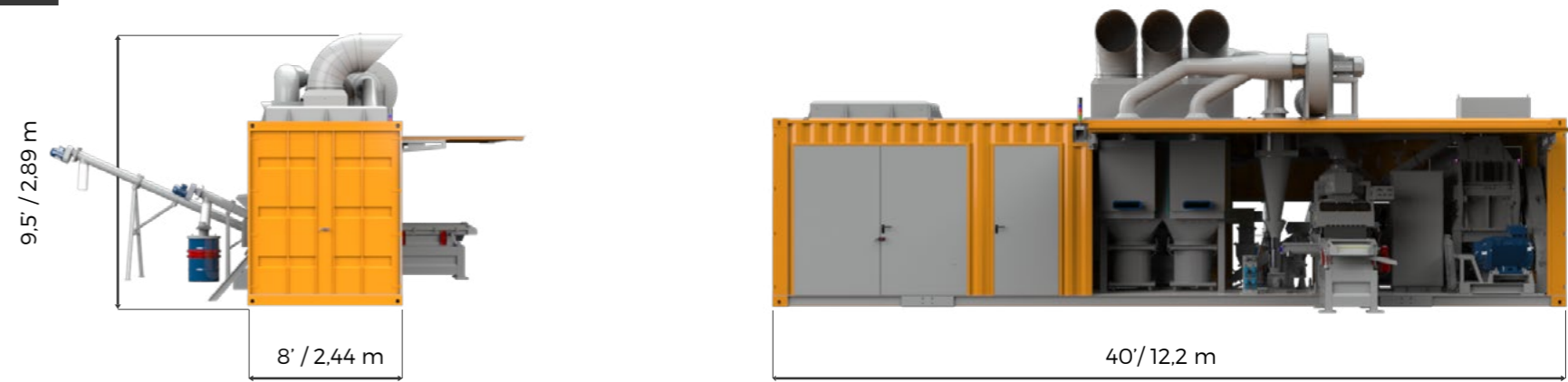

TECHNICAL DATA	CABLEBOX ONE	SHREDDER	GRANULATOR	AIR DEDUSTING SYSTEM
Length	40' / 12,2 m	-	-	-
Width	8' / 2,44 m	-	-	-
Height	9,5' / 2,89 m	-	-	-
Power	300 Hp / 220 kW	50 Hp / 110 kW	100 Hp / 75 kW	-
Weight	64 000 lb / 30T	18 700 lb / 8,5T	12 000 lb / 5,5T	-
Cutting speed	-	140 - 180 RPM	150 - 375 RPM	-
Rotor length	-	1200 mm / 47"	800 mm / 32"	-
Blades	-	24	28	-
Air flow	-	-	-	8500 m3/h - 5000 cfm

Non contractual data

The MaX

Be autonomous in recovering your own raw materials with this ingenious recycling process! **The MaX is a concentrate of innovation and MTB know-how. A minimal investment for high quality return.**

Choosing between productivity, size and quality? With MTB, you get the best without compromise. The MaX is the smallest chopping line ever, combining a robust build, proven separation, and the unmatched service and support MTB is renowned for.

Shredder BVR 845

- Flywheel
- Swing arm pusher
- Regulation hopper

Granulators BAT 445

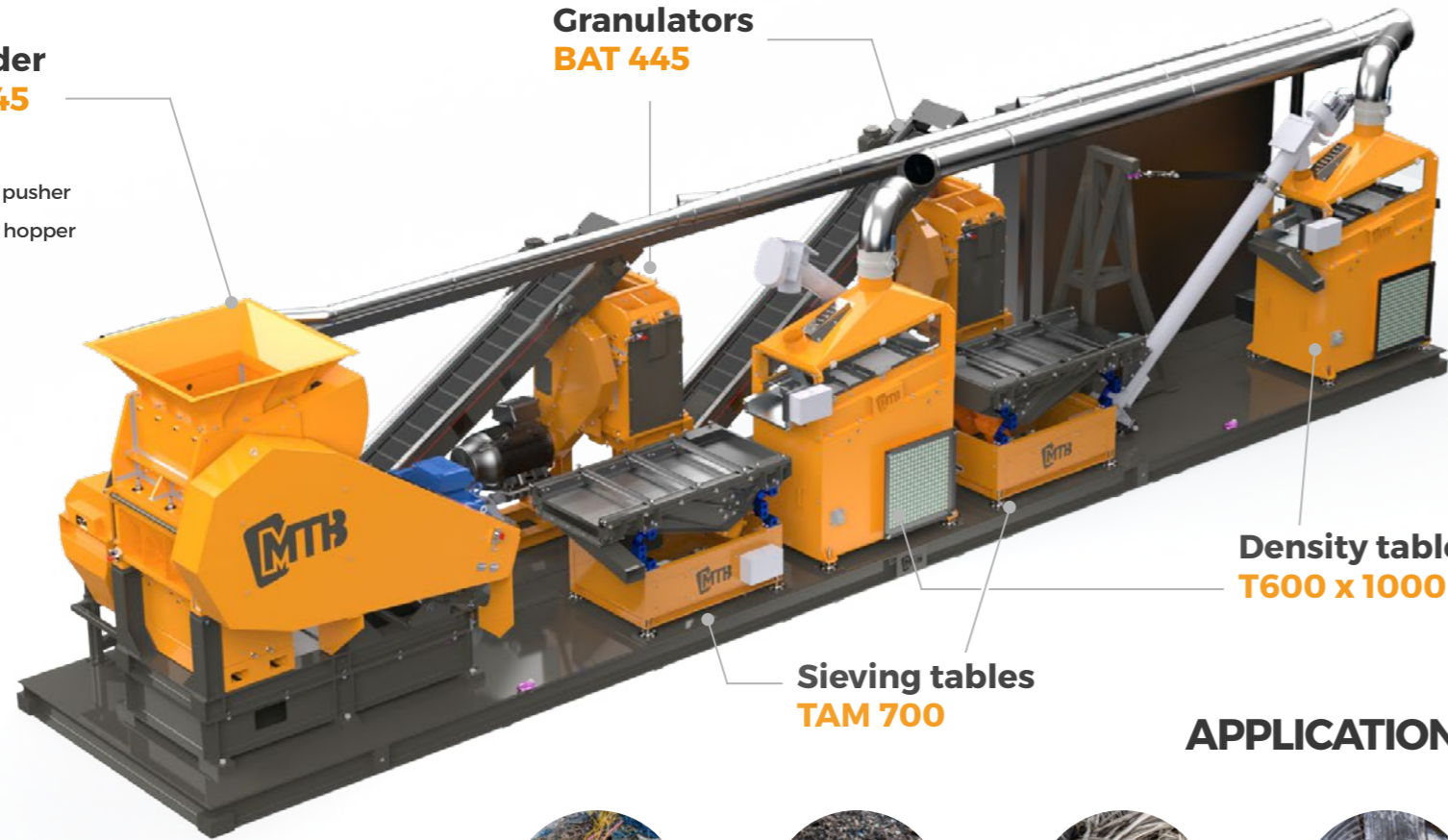

Density tables T600 x 1000

Sieving tables TAM 700

APPLICATION SPECIALTIES



CABLES



SHREDDED WIRES



ACSR

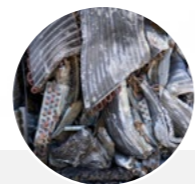

RADIATORS



WIRE HARNESSSES

CAPACITY
up to 1T/h

COMPOSITION

SHREDDING



Compact Shredder : BVR 845

GRANULATION



Compact Granulator :
BAT 445 x2

SORTING



Air Density Table :
T600 x 1000



Sieving Table :
TAM 700

FERROUS EXTRACTION



Magnetic Separator

CLASSIFIED OUTPUT PRODUCTS*



BIG COPPER

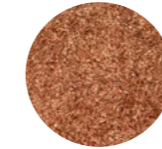

FINE COPPER

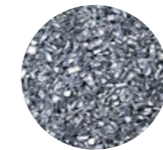

ALUMINUM



FLAKES (OPTIONAL)



PLASTIC



FERROUS INSERT

Option :

- Flakes screening stage
- Extra plastic screening
- Dust collection system
- ACSR option

* Classified non ferrous grades, ferrous,



The MaX

a unique concept with a wide range of relevant features.

PLUGN'RUN SOLUTION

- Pre-assembled onto a 40' container floor, our new MaX solution offers reduced footprint requirements for easy install
- Power connection and a flat concrete slab is all that is required to set up and use this compact chopping line
- Fully integrated solution featuring pre-wiring and pre-ducting to allow fast commissioning
- Mobile, the MaX provides the higher comfort and flexibility of use

MAINTENANCE BENEFITS

- Tapping blade adjustment system duplicated from our larger flagship machineries
- Same blade model on shredder and granulators for easiest spare parts management
- Easy access and opening on all equipment
- Simplified maintenance operations mean reduced downtime and lowest operating costs
- Optimized transmission for easier maintenance and longer consumable life

Technical Data



TECHNICAL DATA	MaX
Power	200 HP - 150 kW
Length	39'12" / 12 m
Width	8' / 2,44 m
Height	9'10" / 3,3 m
Weight	20 T

The MaX's benefits at a glance

- Gradual size reduction in **3 steps** to increase **productivity**
- **One single blade model** for the entire process : the historical one at MTB
- Same robust design replicated from our larger shredders : **extended machines life**
- **Dedusting step** : hoses can be connected to existing systems (sourced by the customer) or with a filter unit supplied in option
- More flexible loading thanks to the **ram-equipped shredder**, eliminating the need of a grapple



Access to the cutting chamber on the BAT 445

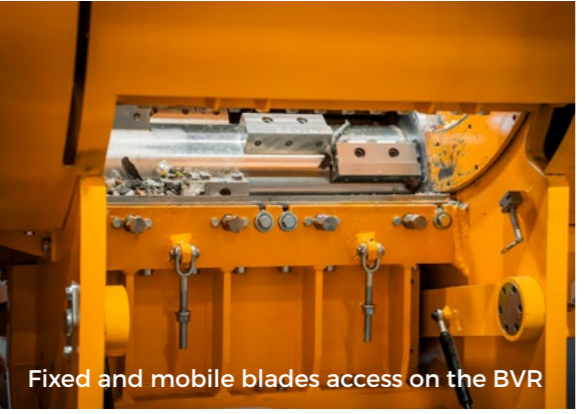

Fixed and mobile blades access on the BVR



Screen and fixed blades access on the

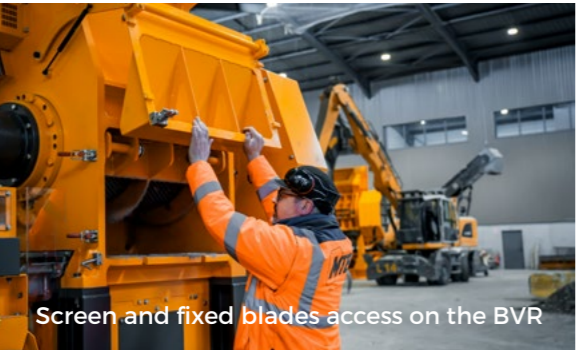

Screen and fixed blades access on the BVR



Easy screen tensioning on the sieving table TAM 700

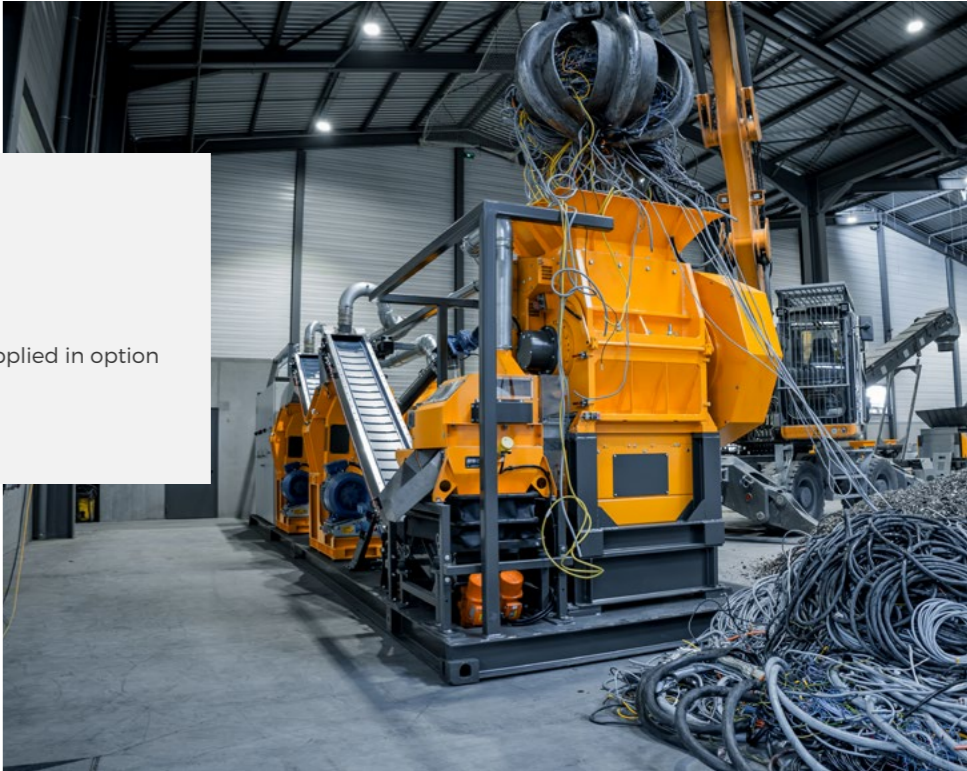

UPGRADEBOX

A containerized refining line

The UPGRADE BOX is the essential complement to cable recycling lines.

It allows rigid granules to be sorted to separate the different metals in a mixture (copper, brass, lead, aluminum, etc.), thus increasing their recovery.

The Upgrade Box is the next step to remove any remaining contamination, to achieve even higher metal purity.



Features and benefits

- + Simultaneous use of RGB, SWIR and IR optical systems: up to 8 frequencies
- + Multi wavelengths led with focusing lens
- + Automatic air pressure regulator
- + Morphological analysis of the product
- + Automatic control and equalization of the vibrators speed
- + Automatic flow management with loopback

TECHNICAL DATA	Upgrade Box
Capacity	3T / h
Dimensions	7,70 x 8,60 x 5,70 m 303 x 338 x 224 inches
Input	Mix of metal granules > 0,5 mm

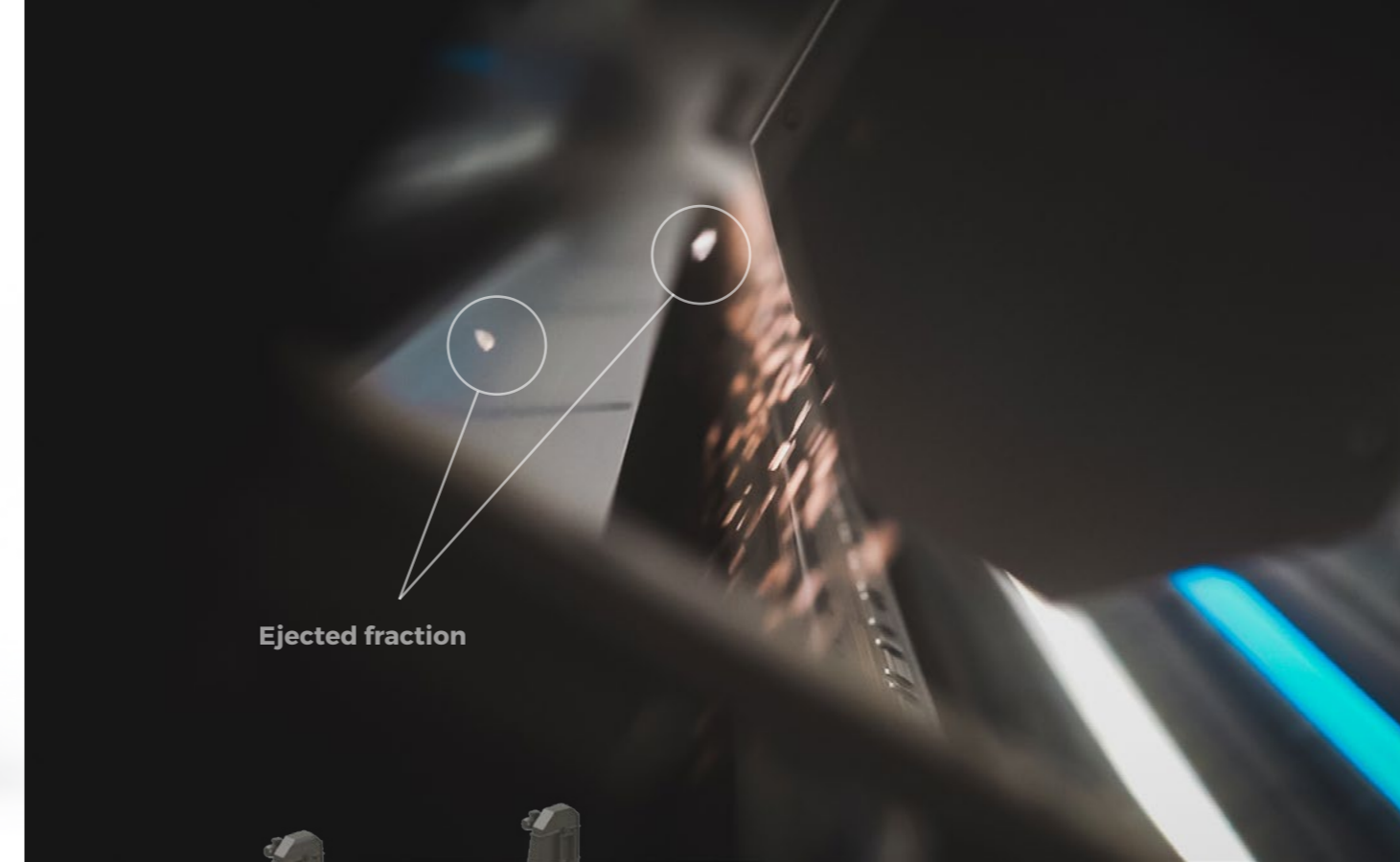

Example of refining aluminum granules



Aluminum granules



Ejected fraction



Pure Aluminum

TIRE BOX

The SHRED' BOX

This part of the process includes:

A shredding unit, which consists of an extremely robust and powerful compact shredder, able to process all common tires, including truck tires and OTR tires.
A granulation module, which includes two granulators reducing the size of the material to achieve the optimum sorting size.

APPLICATION SPECIALTIES



TIRES



TDF



The AIR' BOX

In order to maintain a quick process and easy installation procedures, MTB has equipped the system with an air filtration unit in a separate container. Despite its relative compactness, the AIR'BOX contains a powerful dust collection system essential for an optimized separation of products.

CAPACITY up to 2 T/h

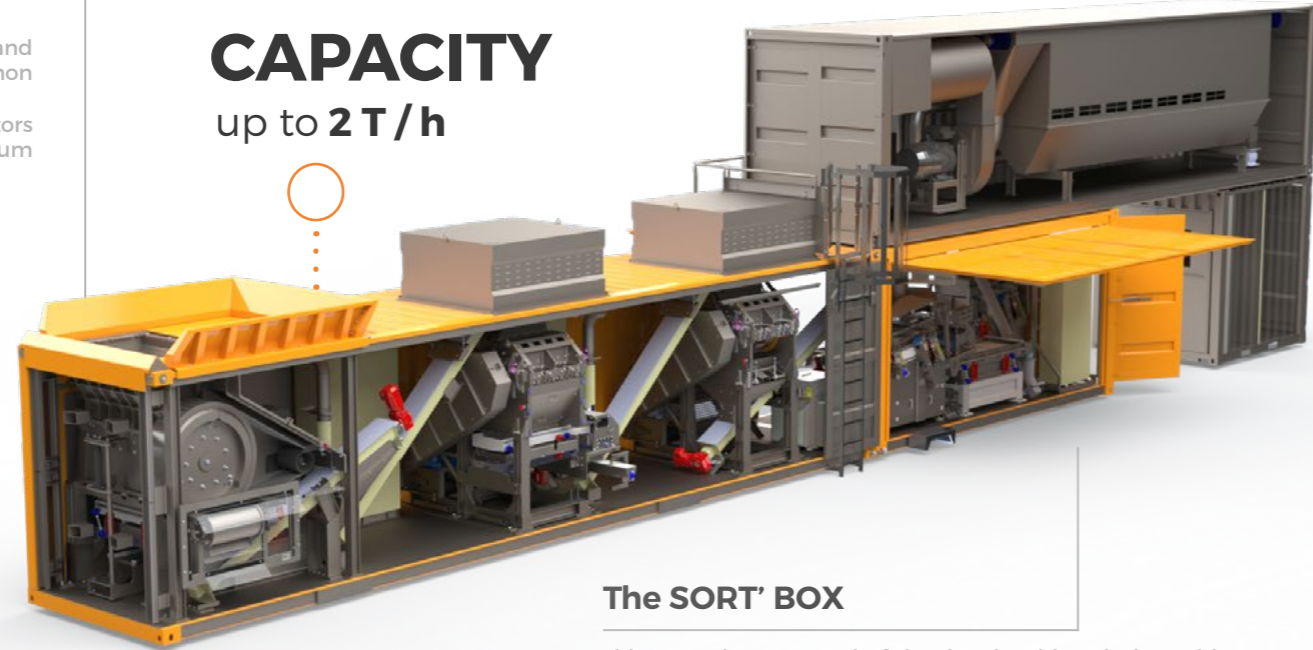

The SORT' BOX

This space is composed of density air tables, sieving tables and magnetic pulleys, which is similar to larger scale recycling lines. It allows the recovery of sorted material at the end of the process as follows: steel wire, fine and big rubber granulate, and textile fiber.

OPTION GATOR BOX

The Gator Box incorporates, in its 20-foot container, the RSX, a two-rotor grinder that can be used both as a rotary shear and a shredder. Its high cutting power and robust reducers allow the RSX to crush a wide range of complex kinds of waste:

Tires, E-Scraps, Large Household Appliances non-cold waste (LHA non-cold), NHIW In order to reach optimal productivity, the Gator Box provides a quick access to the RSX shafts, allowing an easy replacement without disassembling the hopper.

The 10' CONTAINER

The 10' container is dedicated to dust collection and sealing the system. The box is divided in 2 parts:

- The dust collection section
- Independent storage for spare parts or tools



COMPOSITION

SHREDDING



Compact Shredder : BDR 1245

GRANULATION



x 2 Compact Granulators :
BAT 845

SORTING



x2 Air Density Tables :
T600 x 1200



x 2 Sieving Tables :
TAM 700

FERROUS EXTRACTION



Magnetic Separator

CLASSIFIED OUTPUT PRODUCTS*

* Classified non ferrous grades, ferrous,



BIG RUBBER



FINE RUBBER



STEEL WIRE



TEXTILE FIBER

Advantages

MINIMUM SIZE - MAXIMUM EFFICIENCY

- Feeding either by crane, belt conveyor or fork lift
- MTB's Heavy Duty machines
- Power and reliability for both granulation and sorting
- Designed to reach up 2 tons per hour capacity may vary upon tire quality
- Output products: rubber granulate, steel wire and textile
- Automatic bin feeder with visual control and level sensor

OPTIONS

- Gator Box
- Hydraulic pusher option available on the Gator Box
- Optional hydraulic system for BDR 1245 and swing doors
- Dust dumpster
- Output containers
- Intermediate magnetic separator
- Maintenance tool assistance

PLUG & RECYCLE

- User-friendly, just plug in and start recycling
- 1 assembly operation only: the external 11770 CFM dust extraction unit (20 000 m³/h)
- Personalized customer support: Training of operators before BOX installation

COMPACT & GREEN

- Turnkey cable recycling line in a container
- Designed to reduce dust emissions drastically
- Intuitive and integrated monitoring system



TIREBOX

Technical Data



TECHNICAL DATA	TIREBOX	SHRED'BOX 40'	SORT'BOX 20'	AIR'BOX 40'	10' CONTAINER	GATOR BOX <small>OPTION</small>	Main equipment specs.		
							PRESHREDDER	GRANULATOR	SHEAR & RIPPER <small>OPTION</small>
Lenght	80' 05" / 24,40 m	39' 12" / 12,19 m	19' 10" / 6,06 m	39' 12" / 12,19 m	9' 8" / 2,99 m	19'10" / 6,06 m	-	-	-
Width	8' / 2,44 m	8' / 2,44 m	8' / 2,44 m	8' / 2,44 m	8' / 2,44 m	8' / 2,44 m	-	-	-
Height	19' 20" / 5,80 m	9' 6" / 2,90 m	9' 6" / 2,90 m	9' 6" / 2,90 m	9' 6" / 2,90 m	9'6" / 2,90 m	-	-	-
Power	500 Hp / 375 kW	345 Hp / 253 kW	35 Hp / 26 kW	125 Hp / 90 kW	-	74 Hp / 2 x 55 kW	125 Hp / 90 kW	100 Hp / 75 kW	74 Hp / 75 kW
Weight	121 000 lb / 54T	66 000 lb / 31 T	22 000 lb / 9 T	24 000 lb / 11 T	6 600 lb / 3T	49 000 lb / 22 T	16 000 lb / 7,5T	12 000 lb / 5,5T	42 000 lb / 19 T
Cutting speed	-	-	-	-	-	-	140 - 180 RPM	150 - 375 RPM	0 - 20 RPM
Rotor length	-	-	-	-	-	-	49" / 1 245 mm	32" / 800 mm	46" / 1160 mm
Blades	-	-	-	-	-	-	24	28	20

DRYCELLBOX

BATTERY SCRAP RECYCLING

Without electrolyte

Air treatment system

HEPA FILTER

Densification

Dry mechanical sorting

INFEED CONVEYOR

1 T/H

Shredding

APPLICA-

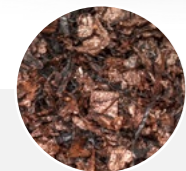

BATTERY SCRAP

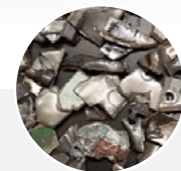

CASINGS



BLACK MASS



LIGHT PLASTIC FOILS



ALUMINUM



COPPER

CLASSIFIED OUTPUT PRODUCTS*

CAPACITY
up to 1T/h

Advantages

- Compact turnkey system
 - Rapid and easy installation and startup
 - Complies security norms
 - Centralized control cabinet POWERBOX
 - High quality of output products
-
- Custom-made MTB concept
 - Duplicated robustness of our large scale installations
 - Depth sorting of cases or foils baling option available
 - Training and ultra-responsive customer service



* Classified non ferrous grades, ferrous, plastics



A keen sense of customer support

Customer service

We're here to advise, troubleshoot and supply spare parts at short notice.

To improve your yields and avoid any unexpected maintenance, our experts set up periodic preventive maintenance controls.

Installation - MTB Service

Our team of MTB technicians travel the world to commission your installations.

Specialized in maintenance and repairs, they will support and advise you in your daily activity

Training and coaching

Our experts will train you before commissioning the machines, to give you the keys to success. The team ensures that your employees master all the parameters of our equipment for an optimized performance.

Eco-design support

Our eco-innovation team, the group's R&D unit, supports manufacturers in their circular economy initiatives.

We offer 4 levels of support :

Awareness / Investigation / Implementation / Development



Address : Parc d'activité des Balmes Dauphinoises, 38890, Saint-Chef, FRANCE

Mail : info@mtb.fr

Website : www.mtb.fr

Phone : +33 474 928 768



Visit our website !